

Energy and Exergy Analysis of the Heating Unit Components of Nag Hammadi Fiber Board Company

Saddam H. Abd El-Hamid¹, Ahmed A. Abd El-Rahman², Ahmed N. Shmroukh^{3, □}, Nouby M Ghazaly³

(<https://orcid.org/0000-0003-4408-8684>)



Abstract In this study, exergy and energy analysis are studied to understand and examine the heating unit performance in Nag Hammadi Fiber Board Company (NFB) with a capacity of 22 MW. The heating unit utilizes natural gas and biofuel together, where the combustion chamber is designed to burn natural gas and wood dust at the same time to decrease the operating cost of the heating unit. The main purpose of heating unit is to burn natural gas and biofuel to supply the manufacturing processes in fiber board production line by hot flue gases for dryer unit and saturated steam for the digestion unit. The heating unit consists of combustion chamber, heat exchanger and steam generator. There is no heat transfer inside the combustion chamber except heat losses through the wall of the combustion chamber. The exergy and energy efficiencies for combustion chamber are found to be 74 % and 42 %, respectively, for heat exchanger are found to be 85 % and 51 %, respectively, for steam generator are found to be 78 % and 30 %, respectively and for heating unit totally are found to be 64 % and 31 %, respectively. This study is carried out to identify and quantify the exergy and energy losses in the heating unit components.

Keywords: Energy analysis; Exergy efficiency; Fiber board; Combustion; Heating.

1 Introduction

Received: 21 September 2022/ Accepted: 30 October 2022

□ Ahmed N. Shmroukh Author, ahmed.shmroukh@eng.svu.edu.eg

1. Nag Hammadi Fiber Board Company, Qena, Egypt.

2. Aluminum Company of Egypt, Nag Hammadi, Qena, Egypt.

3. Mechanical Engineering Department, Faculty of Engineering - South Valley University, Qena, Egypt.

Today, increasing the energy demand is a major challenge facing the researchers all over the world. All over the world there is increasing in energy demand, but the energy resources are limited. So, it becomes necessary to understand the mechanisms which degrade the quality of energy (ability to do work) [1]. Several researches have been done to analysis both energy and exergy of heat exchangers specially heating units [2]. Fard and Pourfayaz [3] analyzed the exergy of heat exchanger network in a complex natural gas refinery. They demonstrated that the total exergetic efficiency of the tested heat exchanger network was reached about 62.8% which could be increased to reach 84.2%, with some suggesting improvements on the insufficient heat exchangers. moreover, Rauch et al [4] developed a mathematical model for analyzing the exergy of several heat exchanger types. They concluded that, it is possible to quantify both exergy destruction ratio and exergy destruction to effectiveness in respect to a higher number of streams passing through parallel and counter flow heat exchangers. While, Esen et al [5] investigated experimentally both energy and exergy efficiencies of underground heat exchanger. They found that for heating season, both energetic and exergetic efficiencies of the demonstrated underground heat exchanger were increased with increasing the ground temperature (heat source). Furthermore, increasing the ambient temperature decreased the exergy efficiency of the underground heat exchanger.

1.1-Exergy definition

The first law of thermodynamics is usually used to the energy utilization, however it is unable to account the energy quality [6]. Therefore, a more relevant parameter called exergy which consequent of

thermodynamics second law, is helpful for determining the useful work potential of a given amount of energy at specified state. Evaluation of exergy is a useful technique for estimating the available work in processes, efficiency, and energy quality [7]. Moreover, it specifies the system maximum performance [8]. When the system reached equilibrium with its surroundings, the obtained maximum useful energy can be defined as the exergy term [9]. The analysis of exergy has been widely used in several applications such as performance evaluation, simulation design and of thermo-chemical and thermal systems. Exergy can be destroyed or lost due to irreversibilities of a process and this provides a measure of the thermodynamic losses in the system and help to locate and quantify wasteful energy utilization in the process [10].

1.2-System description

The main purpose of NFB is the production of medium density fiberboard (MDF) from sugarcane bagasse (sugarcane detritus). The production process is achieved through a lot of manufacturing processes as shown in figure 1. The production process is in order as follows, washing, digesting, refining, gluing, drying, matt forming, cold pressing, hot pressing and finally finishing the surface by sanding machines. The function of heating unit in the manufacturing process is supplying the fiber digester by saturated steam at 15 bar and supplying the dryer by hot flue gases. The detritus of sanding machines (dust) is transferred to the combustion chamber of the heating unit. In the heating unit the combustion chamber utilizing natural gas and biofuel (dust) to supply the heating unit by high temperature combustion products as shown in figure 2.

1.3- Study objectives

This study aims to calculate the efficiency of the heating unit components by the first and second laws of thermodynamics with the variation of the natural gas and biofuel ratio.

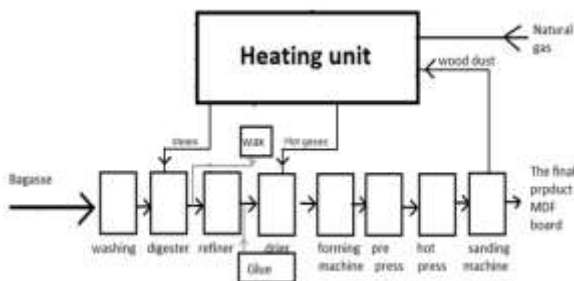

Figure 1. Schematic diagram of the manufacturing process in (NFB).

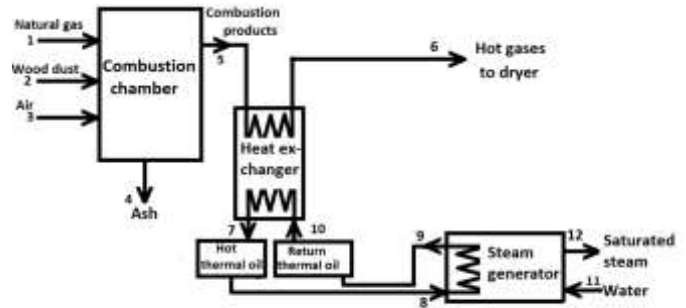

Figure 2. Schematic diagram of the heating unit in (NFB).

2 Methodology

In the light of the first law and the second law of thermodynamics, energy and exergy balance are applied in all system components.

2.1 Combustion chamber first law analysis.

Combustion chamber is used to burn the fuel and produce high temperature combustion products without any heat transfer inside the combustion chamber except heat losses through the wall of the combustion chamber as shown in figure 3. At steady state and with negligible kinetic and potential energies, energy balance equations can be expressed as the following [11].

$$\dot{E}_{in} - \dot{E}_{out} = (dE_{system} / dt) = 0 \quad \text{for steady state} \quad (1)$$

$$\dot{E}_{in} = \dot{E}_{out} \quad (2)$$

$$\dot{m}_f h_f + \dot{m}_a h_a = \dot{m}_p h_p \quad (3)$$

The first law efficiency can be written as:

$$\eta = (\dot{m}_p h_p) / (\dot{m}_f h_f) \quad (4)$$

2.2 Combustion chamber second law analysis.

The maximum power output of reversible power is determined from the exergy balance is applied to combustion chamber assuming the environment

temperature is 25°C ($T_0=298\text{K}$), at steady state and with negligible kinetic and potential energies. The exergy balance formulation can be expressed by using this methodology [12].

For steady state

$$\varepsilon_{in} - \varepsilon_{out} - \varepsilon_{destroyed} = (d\varepsilon_{system}/dt) = 0 \quad (5)$$

$$(m_f \varepsilon_f + m_a \varepsilon_a) - m_p \varepsilon_p - I_c = 0 \quad (6)$$

While, the second law efficiency can be expressed as

$$\psi = (m_p \varepsilon_p) / (m_f \varepsilon_f) \quad (7)$$

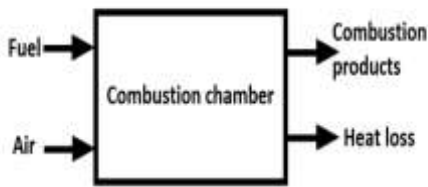

Figure 3. Combustion chamber schematic diagram

2.3 Heat exchanger first law analysis.

The heat exchanger is a device where two moving fluids can exchange heat. Heat is transferred through the wall from the hot side to the cold side, where no work interaction is involved ($W = 0$) and negligible potential and kinetic energies for both fluid streams. Mainly, the heat exchanger outer shell is insulated perfectly to prevent the loss of heat to the surrounding medium [13]. The heat exchanger energy balance is illustrated in figure 4.

The energy balance equations can be written as [6],[8],[11]:

$$\dot{E}_{in} - \dot{E}_{out} = (dE_{system}/dt) = 0 \quad \text{for steady state} \quad (1)$$

$$(\dot{m}_5 h_5 + \dot{m}_{10} h_{10}) - (\dot{m}_6 h_6 + \dot{m}_7 h_7) = Q \quad (8)$$

While, the first law efficiency can be expressed as:

$$\eta = (\dot{m}_6 h_6 + \dot{m}_7 h_7) / (\dot{m}_5 h_5 + \dot{m}_{10} h_{10}) \quad (9)$$

2.4 Heat exchanger second law analysis.

The exergy balance formulation can be expressed by using this methodology [8],[12].

The second law efficiency for steady state can be written as

$$\varepsilon_{in} - \varepsilon_{out} - \varepsilon_{destroyed} = (d\varepsilon_{system}/dt) = 0 \quad (5)$$

$$\psi = (\dot{m}_6 \varepsilon_6 + \dot{m}_7 \varepsilon_7) / (\dot{m}_5 \varepsilon_5 + \dot{m}_{10} \varepsilon_{10}) \quad (10)$$

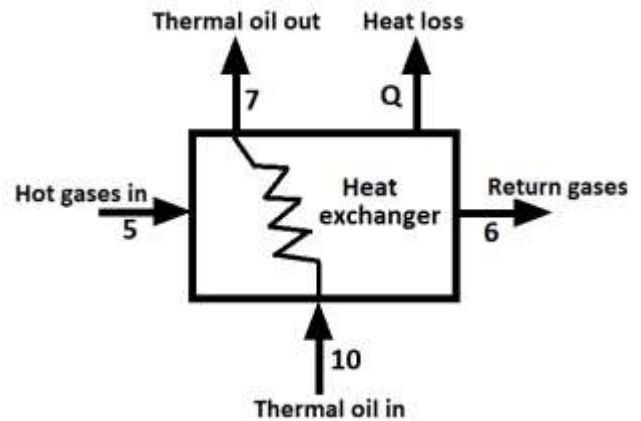

Figure 4. Heat exchanger schematic diagram.

2.5 Steam generator first law analysis.

steam generator receives saturated liquid water at 25°C and delivers saturated steam at 15 bar utilizes high temperature thermal oil as shown in figure 6. At steady state and with negligible potential and kinetic energies, energy balance can be written as the following [6],[11].

$$\dot{E}_{in} - \dot{E}_{out} = (dE_{system} / dt) = 0 \quad \text{for steady state} \quad (1)$$

$$(\dot{m}_8 h_8 + \dot{m}_{11} h_{11}) - (\dot{m}_9 h_9 + \dot{m}_{12} h_{12}) = Q \quad (11)$$

The first law efficiency can be expressed as:

$$\eta = (\dot{m}_9 h_9 + \dot{m}_{12} h_{12}) / (\dot{m}_8 h_8 + \dot{m}_{11} h_{11}) \quad (12)$$

2.6 Steam generator second law analysis.

Energy balance formulation can be expressed by using this methodology [6],[11].

The second law efficiency for steady state can be written as

$$\varepsilon_{in} - \varepsilon_{out} - \varepsilon_{destroyed} = (d\varepsilon_{system} / dt) = 0 \quad (5)$$

$$\psi = (\dot{m}_9 \varepsilon_9 + \dot{m}_{12} \varepsilon_{12}) / (\dot{m}_8 \varepsilon_8 + \dot{m}_{11} \varepsilon_{11}) \quad (13)$$

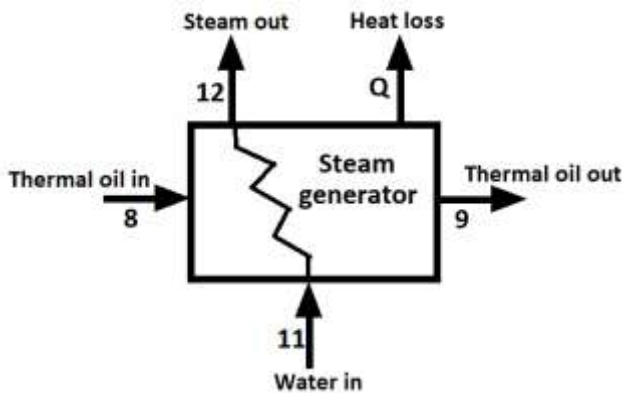

Figure 6. Steam generator schematic diagram.

2.7 Heating unit first law analysis.

Heating unit utilizes fuel dust to produce high temperature products and saturated steam as shown in fig. 7. For heat exchanger is shown in figure 4, energy balance can be expressed as [12]:

$$\dot{E}_{in} - \dot{E}_{out} = (dE_{system} / dt) = 0 \quad \text{for steady state} \quad (1)$$

$$(\dot{m}_f h_f + \dot{m}_{11} h_{11}) - (\dot{m}_6 h_6 + \dot{m}_{12} h_{12}) = Q \quad (14)$$

The first law efficiency can be written as:

$$\eta = (\dot{m}_6 h_6 + \dot{m}_{12} h_{12}) / (\dot{m}_f h_f + \dot{m}_{11} h_{11}) \quad (15)$$

2.9 Heating unit second law analysis.

Energy balance for steady state can be written as the following [6],[11].

$$\varepsilon_{in} - \varepsilon_{out} - \varepsilon_{destroyed} = (d\varepsilon_{system} / dt) = 0 \quad (5)$$

The second law efficiency can be written as

$$\psi = (\dot{m}_6 \varepsilon_6 + \dot{m}_{12} \varepsilon_{12}) / (\dot{m}_f \varepsilon_f + \dot{m}_{11} \varepsilon_{11}) \quad (16)$$

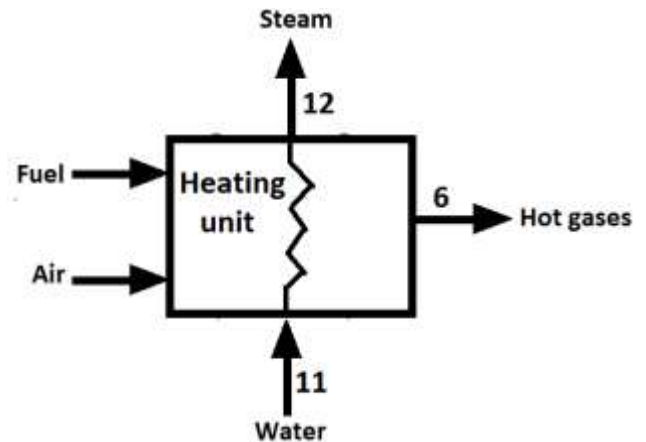

Figure 7. Heating unit schematic diagram.

3 Results and Discussion

The energy and exergy efficiencies are calculated for system components. The heating value of natural gas and wood dust (sugarcane bagasse) is taken as 50 MJ/kg and 17 MJ/kg. The specific exergy of natural gas and wood dust (sugarcane bagasse) is taken as 49.45 MJ/kg and 13.2 MJ/kg [14]. Assuming environment temperature is 25°C.

3.1- Combustion chamber

Applying both first and second laws of thermodynamics to the combustion chamber, the enthalpy and entropy values are obtained from [15]. The applied balance contains the solid fuel, air, combustion products and the heat loss. The results are presented in fig 8. The change of energetic and exergetic efficiencies for the combustion chamber with the change of natural gas percent in the total fuel is shown in fig (8). Figure 8 shows that the energetic and exergetic efficiencies for the combustion chamber decrease with decreasing the natural gas percentage and increasing the biofuel (wood dust) percentage, because it is easy to get a complete combustion in natural gas however, it is difficult to get a complete combustion in the biofuel, therefore, the efficiency is decreased with increasing the biofuel percentage.

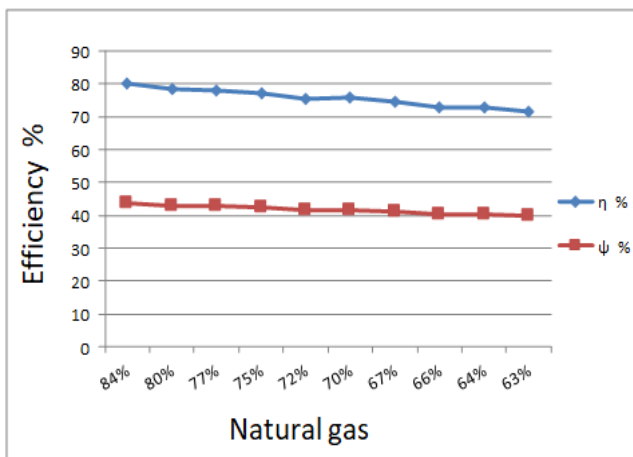

Figure 8. Change of energetic and exergetic efficiencies for the combustion chamber with the change in natural gas percent in the total fuel.

3.2- Heat exchanger

Applying both the first and second laws of thermodynamics to the heat exchanger at different loads percentage. The applied balance contains thermal oil changes, the hot gases flow and the heat loss. The curves show the change of exergetic and energetic efficiencies for the heat exchanger with the change in load percent as shown in fig 9. Figure 9 illustrates that the second law efficiency increases with the load increasing due to the increasing of the temperature of the second fluid (thermal oil) of the heat exchanger in high loads condition.

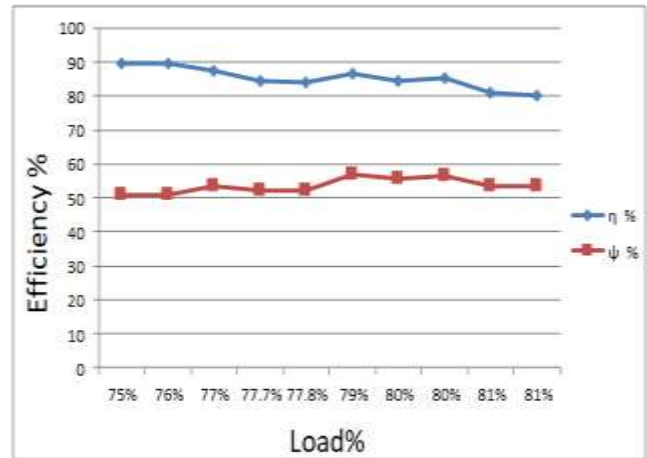

Figure 9. Heating exchanger exergetic and energetic efficiencies.

3.3 Steam generator

Applying the first and the second laws of thermodynamics on the steam generator. The applied balance consists of water and steam flow, thermal oil changes and the heat losses. The curves show the change of exergy and energy efficiencies for the steam generator with the change in load percent as shown in fig (10). Figure 10 demonstrates that there is a slight decrease in the efficiency with increasing the load, where the increasing in the load of the steam generator means change in steam mass flow rate only without any change in the pressure.

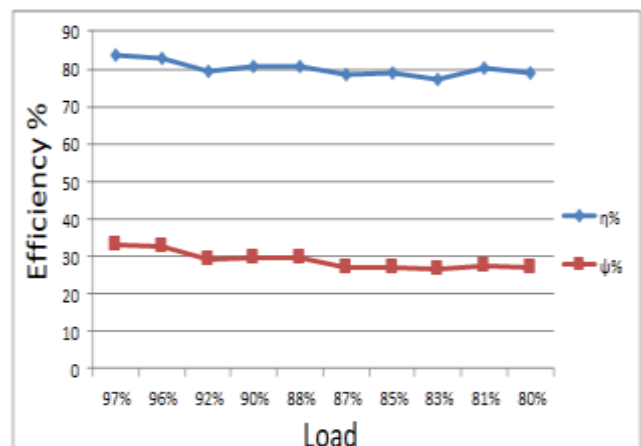

Figure 10. Exergy and energy efficiencies for the steam generator.

3-4 Heating unit (overall system)

Applying both the first low and second law of thermodynamics on the heating unit totally. The applied

balance contains the whole water and steam flow, air an fuel flow and the heat losses The curves show the change of exergetic and energetic efficiencies for the heating unit with the change in load percent as shown in fig 11. Figure 11 illustrates that in high loads, the percent of biofuel in the total fuel is increased to get economical operation, therefore the efficiency is decreased with increasing the loads of the heating unit.

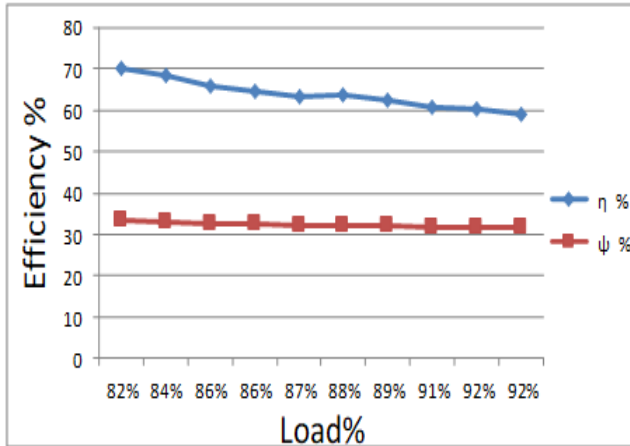

Figure 11. Heating unit change of exergetic and energetic efficiencies.

The curves show that the exergetic and energetic efficiencies of the combustion chamber decrease with the decreasing of natural gas percent and increasing of biofuel (wood dust) percent. The reason of this that it is easy to get a complete combustion in natural gas, but it is difficult to get a complete combustion in the biofuel. For heat exchanger the energetic efficiency decreases with the increasing the load. For steam generator the exergetic and energetic efficiencies decrease with the decreasing the load. For heating unit totally, the exergetic and energetic efficiencies decrease with the increasing the load.

7 Conclusion

Although the efficiencies of combustion chamber decrease with the increasing of biofuel (wood dust) percent but the operating with high biofuel percent is the best because the biofuel is cheaper than natural gas. During peak load the best choice is increasing natural gas percent to supply the heating unit by extra power because the curves show that the natural gas is more effectiveness than biofuel. However, a detailed cost analysis needs official information from the company and this is not available in this time.

List of symbols

h_f	fuel specific enthalpy, kJ/kg
h_a	air specific enthalpy, kJ/kg
h_p	products specific enthalpy, kJ/kg
\dot{m}_a	air mass flow rate, kg/s
\dot{m}_{BF}	biofuel (wood dust) mass flow rate, kg/s
\dot{m}_f	fuel mass flow rate, kg/s
\dot{m}_{NG}	natural gas mass flow rate, kg/s
\dot{m}_p	products mass flow rate, kg/s
$\dot{m}_{Products}$	combustion products mass flow rate, kg/s
Q	heat loss
$T_{Products}$	combustion products temperature, K

Greek symbols

η	energy efficiency
ψ	exergy efficiency
ε	exergy
ε_a	exergy of air
ε_f	exergy of fuel
ε_p	exergy of products

References

- [1] Barinaadaa Thaddeus Lebele-Alawa, Jerry Mike Asue "Exergy analysis of kolocreek gas-turbine plant" Canadian journal on mechanical science &engineering Vol. 2 No. 8.December 2011.
- [2] Mohsen Mehdizadeh-Fard, Fathollah Pourfayaz, Akbar Maleki. "Exergy analysis of multiple heat exchanger networks: An approach based on the irreversibility distribution ratio". Energy Reports. 7 (2021) pp. 174-193.
- [3] Mohsen Mehdizadeh-Fard, Fathollah Pourfayaz. "Advanced exergy analysis of heat exchanger network in a complex natural gas refinery". Journal of Cleaner Production. 206, (2019) pp. 670-687.
- [4] Martina Rauch, Saša Mudrinić, Antun Galovi. "Detailed Analysis of Exergy Destruction of All Basic Types of Heat Exchangers". Processes. 10 (2022), 249.
- [5] Hikmet Esen, Mustafa Inalli, Mehmet, Esen, Kazim Pihitli. "Energy and exergy analysis of a ground-coupled heat pump system with two horizontal ground heat exchangers". Building and Environment. 42 (2007) pp. 3606-3615.
- [6] R. Saidur, J.U. Ahmed, H.H. Masjuki "Energy, exergy and economic analysis of industrial boilers" Energy policy 38 (2010) 2118-2197
- [7] Omid Mahian, Mohammad Reza, Alibakhsh Kasaeian, Seyed Hossein Mousavi "Exergy analysis in combined heat and power systems" Energy conversion and management 226 (2020) 113467.
- [8] Saidur R, Boroumandjazi G, Mekhilef S, Mohammed HA "A review on exergy analysis of biomass based fuels" Renew. Sustain. Energy Rev. 2012;16(2): 1217–22
- [9] Ahamed, J.U., Saidur, R., Masjuki, H.H., Mekhilef, S., Ali, M.B., Furqon, M.H. "An application of energy and exergy analysis in

- agricultural sector of Malaysia” Energy Policy, December 2011, Pages 7922-7929.
- [10] Wark, K., & Richards, D. E. (1999). Thermodynamics(6). WCB McGraw-Hill. ISBN: 0070683050(hb), 0073038482(cd), 9780070683051(hb), 9780073038483(cd).
- [11] Cengel, Y. A. and Boles, M. A. (2006), Thermodynamics: An Engineering Approach, 5th Edition, McGraw Hill.
- [12] M. Hasanuzzaman, R. Saidur and N. A. Rahim “Energy, exergy and economic analysis of an annealing furnace” International journal of physical science vol. 6(6), pp. 1257-1266, 18 March, 2011.
- [13] Ahmed N Shmroukh, Essam Hares, Osama Hamdy, Mostafa Abouelsoud “ Evaluation of New Composite Adsorbents for Solar-Driven Adsorption Refrigerator” SVU-International Journal of Engineering Sciences and Applications 2 (2021) 76-81.
- [14] Sanober Khattak, Richard Greenough, Vishal Sardeshpande, Neil Brown “ Exergy analysis of a four pan jaggery making process” Energy reports 4(2018) 470-477.
- [15] Sonntag, R. E. and Borgnakke, C. (2007) Introduction to engineering thermodynamics. 7th ed. Hoboken, N.J.: John Wiley